

*“The Original”*

**N.A. Woodworth**

Workholding Worldwide

**FORKARDT**

SUPPORTED BY  
**FORKARDT**

**UBL**

**Universal Ball-Lok Chuck**



**WORKHOLDING SOLUTIONS WORLDWIDE**

# Universal Ball-Lok (UBL) Chuck

N.A. Woodworth's comprehensive line of workholding begins with the "UBL". It is "The Original" used industry wide and it sets the standard for all other power chucks.

## The features of the UBL include:

- Easy conversion from external to internal chucking
- Positive pullback action
- Chucks are internally lubricated and have a sealed design to keep chips and contaminants out
- Jaw homing device allows jaws to compensate for part variations
- Various jaws for different work pieces can be readily interchanged
- Offered in Centralizing and Compensating
- Centralizing chucks put the work piece on the center rotation
- Compensating chucks enable the actuator to float and allow the chuck jaws to engage independently of the chuck center



## Recommended Chucking Ranges

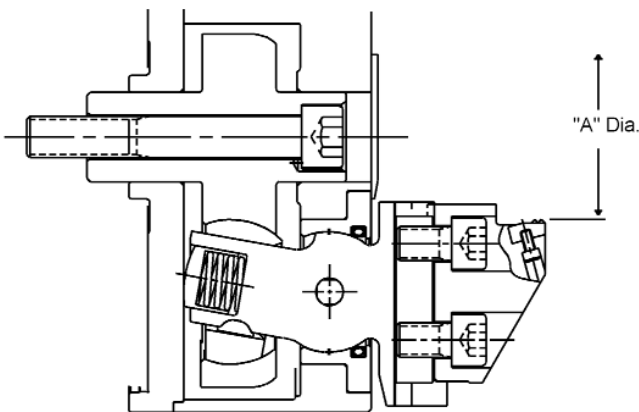

External Mode

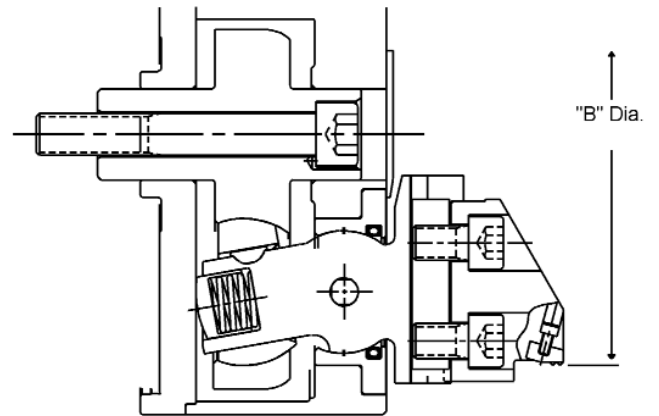

Internal Mode

UBL Size		"A" Diameter External Chucking Range (Recommended)	"B" Diameter Internal Chucking Range (Recommended)
		<i>maximum / minimum</i>	<i>maximum / minimum</i>
160		120 / 14	150 / 70
200		150 / 16	200 / 80
250		200 / 50	230 / 85
300		240 / 65	300 / 130
380		315 / 80	380 / 165
460		390 / 90	455 / 245

The recommended chucking ranges are for general applications. If an application has a part size that exceeds the above maximum or minimum, contact the FORKARDT proposal department for review.

All sizes are in millimeters.

# Features

## Internal and External clamping modes.

### Internal and External clamping modes.

- A. Remove 4 bolts from each front bearing.
- B. Rotate actuator arm 180 degrees (without removing from the chuck body).
- C. Replace and tighten front bolts.

## Positive pull-back action.

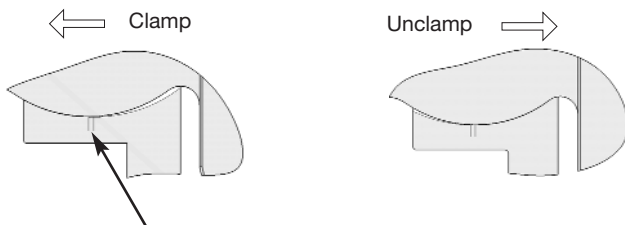

A flat is provided at the center of the spherical diameter. This flat is what enables the pull-back feature. The flat is standard in our bearings, or can be customized for specific needs.

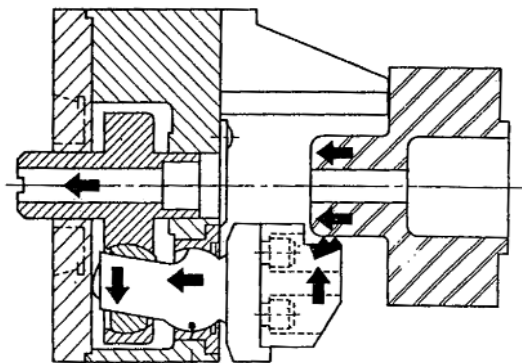

## Homing function of jaws.

“Homing” is the ability of the jaws to rotate up to 5 degrees in either direction. “Homing” allows the jaws to compensate for castings and forgings that are not perfectly round and insures secure and equalized gripping force at all chucking points.

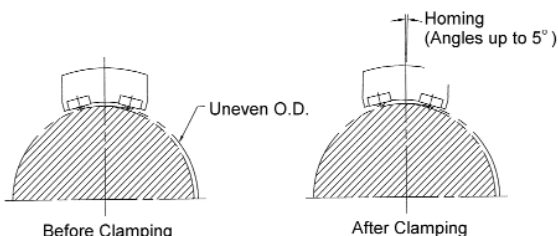

## Ability to grip shorter lengths and tapered diameters.

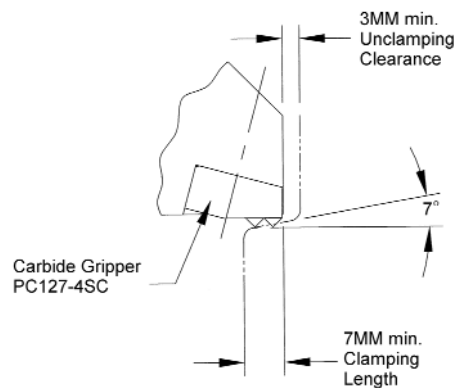

UBL chucks can grip work-pieces having up to a 7 degree taper. With standard jaw design and up to 12 degrees with minor modifications.

## Extended life.

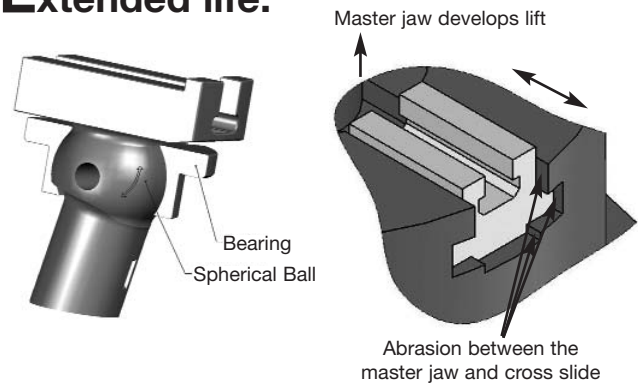

The life of a standard, sliding jaw, power chuck is greatly reduced by abrasion between the master jaws and chuck body. Over time the base jaws will develop lift.

The UBL chucks utilize a spherical ball and bearing design which reduces wear, thus extending the life of the chuck.

## Component inter-changeability.

UBL components are designed and manufactured for inter-changeability. Replacement components can be easily installed; maintaining the original accuracies. Components are in stock and can be promptly delivered.

# Centralizing Type

Centralizing UBL Chucks work by utilizing a one-piece actuator device which allows the chuck jaws to establish the axis of rotation. The diameters being turned will then be concentric to the chucking diameter. The pull back feature insures the work piece against an axial locator which guarantees perpendicularity and parallelism.

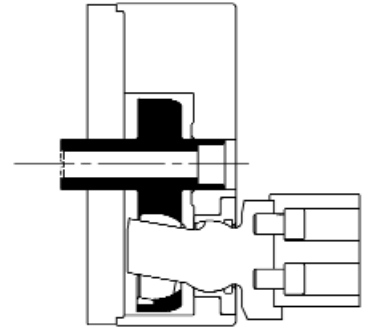

## Practical Examples

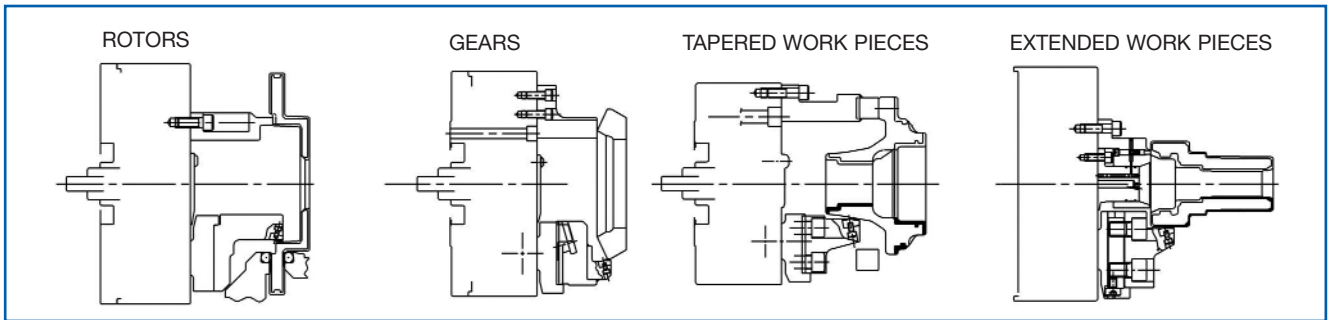

# Compensating Type

Compensating UBL chucks work by utilizing a two piece actuator device which allows the chuck jaws to compensate for any eccentricity between the chucking diameter and the datum diameter. The centralizing device is generally an arbor, plug or center mounted on the face of the chuck. The centralizing device establishes the axis of rotation from the datum diameter in the work piece. The diameters being turned will then be concentric to the datum diameter.

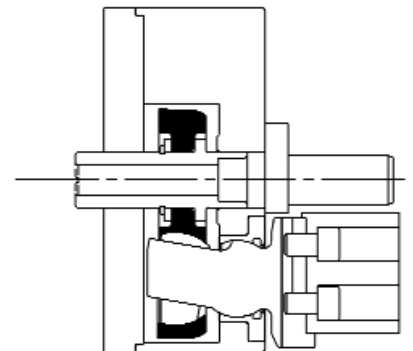

## Practical Examples

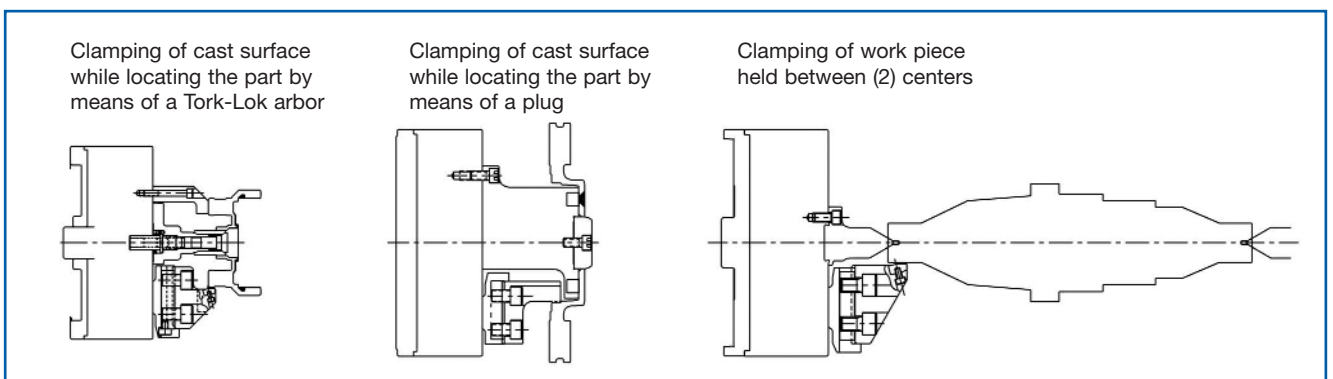

# Specifications

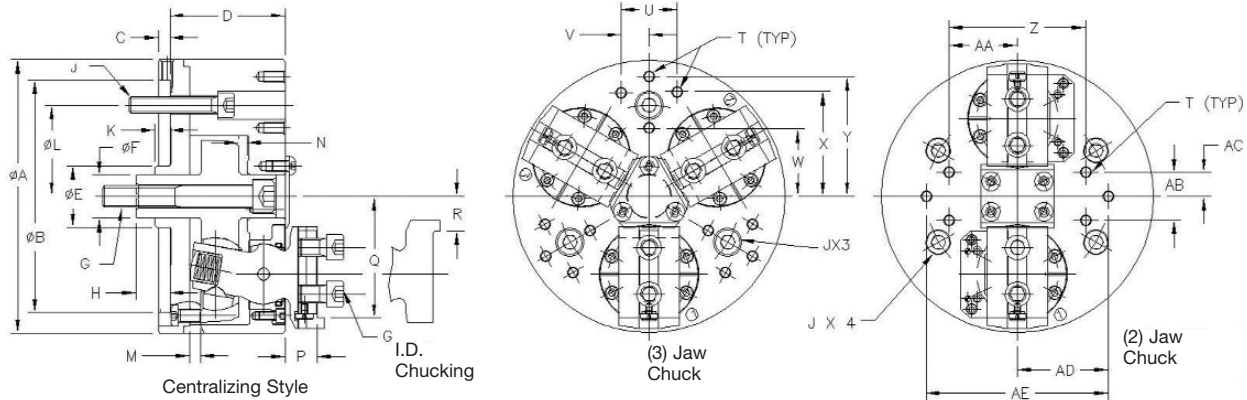

1 KN = 224.81 lbs. (Force)  
1 kg = 2.20 lbs. (Weight)

		Chuck Size					
		160	200	250	300	380	460
<b>CENTRALIZING</b>							
(2/Jaw) Model Number		UBL160010	UBL200010	UBL250010	UBL300010	UBL380010	UBL460010
(3/Jaw) Model Number		UBL160000	UBL200000	UBL250000	UBL300000	UBL380000	UBL460000
<b>COMPENSATING</b>							
(2/Jaw) Model Number		UBL160012	UBL200012	UBL250012	UBL300012	UBL380012	UBL460012
(3/Jaw) Model Number		UBL160002	UBL200002	UBL250002	UBL300002	UBL380002	UBL460002
<b>Dimensions (mm)</b>							
Chuck Diameter	A	160	200	254.1	298.6	381	457.3
Mounting Recess Dia.	B	140	170	220	220	300	380
Depth of Recess	C	8.7	8.7	8.7	8.7	14.3	13.5
Chuck Height	D	72.2	84.2	103.2	103.2	116.7	116.7
Back Plate Boss Dia.	E	42	45	57.2	60	85	120.65
Actuator Dia.	F	30.2	31.8	41.3	41.3	57.15	88.9
Draw Bar Thread	G	M16 x 2	M16 x 2	M20 x 2.5	M20 x 2.5	M24 x 3	M24 x 3
Actuator Position	H	23.5	25.1	28	28	38.7	28
Chuck Mounting Bolt Size	J	M10 x 1.5	M12 x 1.75	M16 x 2	M16 x 2	M20 x 2.5	M24 x 3
Length of Boss	K	6.8	11.1	8.7	8.7	16	8.7
Mounting Bolt Circle Dia.	L	104.8	133.4	171.4	171.4	235	330.2
Actuator Stroke to Full Close	M	5.2	8	7.9	7.9	10.4	10.4
Actuator Stroke to Full Open	N	6.4	6.3	9.7	9.8	11.9	11.9
Total Actuator Stroke	M+N	11.6	14.3	17.6	17.7	22.3	22.3
Jaw Mounting Platform	P	19.4	23.7	29.2	29.2	32.5	32.5
Jaw Ledge (External Grip)	Q	73.03	88.9	112.7	133.35	171.45	209.55
Jaw Ledge (Internal Grip)	R	22.23	25.4	30.14	50.81	69.85	103.95
Jaw Mounting Screw Size	S	M10 x 1.5	M12 x 1.75	M16 x 2	M16 x 2	M20 x 2.5	M20 x 2.5
Tooling Mounting Screw Size	T	M8 x 1.25	M8 x 1.25	M10 x 1.5	M10 x 1.5	M12 x 1.75	M16 x 2
Position of "T" (3) Jaw	U	N/A	N/A	50	50	N/A	N/A
Position of "T" (3) Jaw	V	N/A	N/A	25	25	N/A	N/A
Position of "T" (3) Jaw	W	35	50	60	60	82.5	110
Position of "T" (3) Jaw	X	N/A	N/A	97.5	100	N/A	N/A
Position of "T" (3) Jaw	Y	70	87.5	N/A	N/A	152.5	200
Position of "T" (2) Jaw	Z	80	100	125	210	150	200
Position of "T" (2) Jaw	AA	40	50	62.5	105	75	100
Position of "T" (2) Jaw	AB	N/A	35	45	90	100	200
Position of "T" (2) Jaw	AC	N/A	17.5	22.5	45	50	100
Position of "T" (2) Jaw	AD	85	N/A	N/A	65	N/A	N/A
Position of "T" (2) Jaw	AE	170	N/A	N/A	130	N/A	N/A
Maximum drawbar force (2) Jaw (KN)		17	26	31	35.5	44	44
Maximum static gripping force (2) Jaw (KN)		42	64	75	86	107	107
Maximum drawbar force (3) Jaw (KN)		26	35	44.5	53	66	66
Maximum static gripping force (3) Jaw (KN)		64	85	108	130	160	160
Maximum RPM		5500	4200	3600	3200	2600	2100
Jaw Weight (kg)		1.07	1.87	3.09	3.77	5.87	7.26
Chuck Weight (kg)		11.34	24.95	38.56	54.43	117.93	145.15

280.10.01 E 02/07

# Adapter Plates

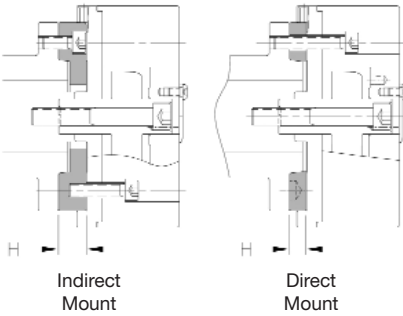

CHUCK SIZE	SPINDLE NOSE	H	TYPE	INDIRECT	DIRECT	L*
UBL 160	4	18	140-K4	D1074053000	n/a	-
	5	14	140-K5	n/a	D1074035000	15
UBL 200	5	24	170-K5	D1074056000	n/a	-
	6	15	170-K6	n/a	D1074036000	15
UBL 250	6	28	220-K6	D1074060000	n/a	-
	8	17	220-K8	n/a	D1074038000	15
UBL 300	6	28	220-K6	D1074060000	n/a	-
	8	17	220-K8	n/a	D1074038000	15
UBL 380	8	32	300-K8	D1074065000	n/a	-
	11	19	300-K11	n/a	D1074040000	20
UBL 460	11	35	380-K11	D1074068000	n/a	-
	15	21	380-K15	n/a	D1074042000	20

\* The length of the chuck mounting bolts must be increased by the amount \*L\* when using these adapter plates.

## General Installation and Maintenance Instructions

### DESCRIPTION

The 3 jaw centralizing Universal Ball-Lok Chuck is a sealed unit, designed for excellent performance, durability and ease of maintenance. The chucking action is achieved by a spherical ball and bearing mechanism. Utilizing its radial and pull-back jaw stroke, draft angles of up to 7 degrees can be safely gripped.

### INSTALLATION

Support the chuck with a sling or eye bolt. With the drawbar in the forward position, thread the drawbar screw into the drawbar. Retract the drawbar at reduced pressure until the chuck contacts the spindle mounting face. Insert the chuck mounting screws and tighten per manufacturer's specifications. Check the installation and jaw stroke by actuating the cylinder. Make sure the unit is well lubricated with FORKARDT approved grease, or equivalent, and actuate the chuck a few times before use.

### JAWS AND GRIPPERS

Jaw safety screws retain the t-nuts in the ball arms. It is very important that they are not removed and remain fully tightened.

The jaw blanks can be bored in position using boring slugs (jaw blanks and boring slugs furnished at additional cost). Check to make sure the jaw mounting bolts are tightened per manufacturer's specifications.

Special jaws can be designed to enhance the utilization of the Ball-Lok chuck. Please consult FORKARDT for further information. Part prints and process sheets will be required to complete the design.

### MAINTENANCE

At a minimum drawbar pull, check to ensure the chuck actuates smoothly. If this test results in a rough or uneven actuation, apply the recommended grease until the relief valve shows signs of excess grease. It is recommended to establish a preventive maintenance schedule. Visual inspection, operator care and periodic PM will enhance and extend the life of the unit. Depending on the severity of this environment, it is recommended that the chuck be disassembled and visually inspected for wear signs in the arms, bearings and actuator every 6 months. If considerable wear is detected, replace the parts immediately.

## Performance Data

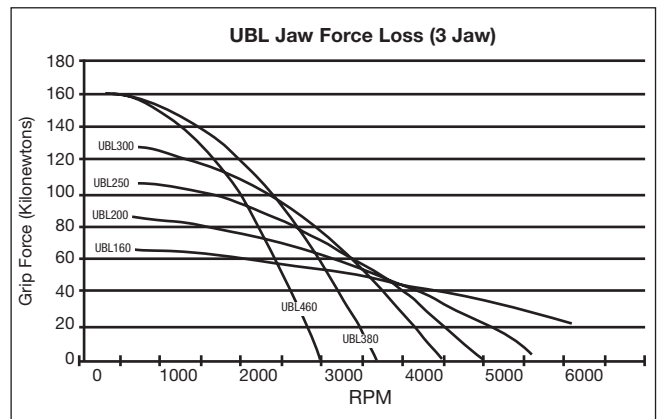
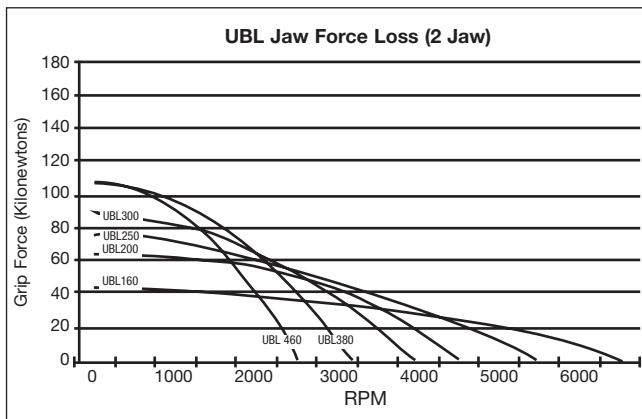

# Component Parts / Service Kits

Description	Included in Kit Numbers					
	1	2	3	4	5	6
B Retaining Ring						1
C Retaining Spacer						1
E Centralizing Pin						3
H Eccentric Bearing		3				
J Spring Cap	3		1			
K Arm Spring	3		1			
L Arm Key	3	3	1			
M Homing Spring	3		1			
N Restrictor Pin	3		1			
O Homing Pin	6		2			
P T-Nut					3	
Q Safety Screw					3	
S Jaw Bolts					6	
T Arm			1			
U Arm Seal	3		1		3	
V Front Bearing			1		3	
X Grease Fitting	4					
Y Relief Valve	1					
A Floating Actuator	<i>Purchase Separately</i>					
D Actuator Support	<i>Purchase Separately</i>					
F Plain Back Adapter	<i>Purchase Separately</i>					
G Actuator	<i>Purchase Separately</i>					
I Housing	<i>Purchase Separately</i>					
R Jaw Blank	<i>Purchase Separately</i>					
W Dust Cover	<i>Purchase Separately</i>					

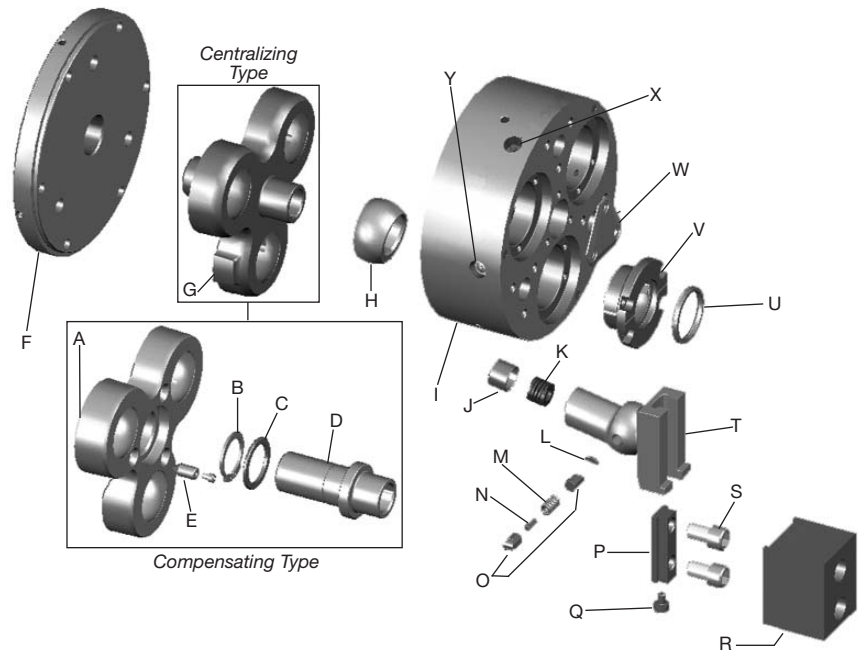

## Service Kits

Kit-Number	HARDWARE	ECC. BEARING	ARM (02)*	TEE-NUT	FRONT BEARING*	COMP.	JAW BLANK
	1	2	3	4	5	6	
UBL 160	UBL160HK	UBL06BK	UBL1602AK	UBL160TN	UBL1602BK	UBL06CK	UBL-6801-B
200	UBL200HK	UBL08BK	UBL2002AK	UBL200TN	UBL2002BK	UBL200CK	UBL-8801-B
250	UBL250HK	UBL10BK	UBL2502AK	UBL250TN	UBL2502BK	UBL250CK	UBL-10801-B
300	UBL250HK	UBL10BK	UBL2502AK	UBL250TN	UBL2502BK	UBL250CK	UBL-12801-B
380	UBL380HK	UBL15BK	UBL3802AK	UBL380TN	UBL3802BK	UBL380CK	UBL-15801-BM
460	UBL380HK	UBL15BK	UBL3802AK	UBL380TN	UBL3802BK	UBL380CK	UBL-18801-BM

\*These kits are set up for use with our standard UBL chuck using standard pull-back bearings. Please specify if "non" pull-back bearings are required.

## Solid Carbide Inserts for Chuck Jaws

- REPLACEABLE
- INCREASE LIFE OF TOP JAWS
- REDUCE CHUCK JAW INVENTORY

Install these rapid-change, long-life inserts in your chuck jaws. After an extensive period of maintenance-free service, inserts can be easily and quickly replaced without the necessity of costly down-time.

Both styles offer positive gripping on rough or smooth surfaces of castings, forging, etc.

Angle-Lok inserts offer additional advantages - permit tools to come closer to the top of the jaws and provides clamping on narrow chucking land.



Angle-Lok style



Round style

See Insert Catalog for additional styles and sizes

**WORKHOLDING SOLUTIONS  
WORLDWIDE**



**L O C A T I O N S      W O R L D W I D E**

**FORKARDT DEUTSCHLAND GMBH**  
 Heinrich-Hertz-Str. 7  
 D-40699 Erkrath  
 Tel: (+49) 211-25 06-0  
 Fax: (+49) 211-25 06-221  
 E-Mail: info@forkardt.com

**FORKARDT SCHWEIZ AG**  
 Industriestrasse 3  
 CH-8307 Effretikon  
 Tel: (+41) 52-3 5531 31  
 Fax: (+41) 52-3 4352 40  
 E-Mail: info-ch@forkardt.com

**FORKARDT FRANCE S.A.R.L.**  
 28 Avenue de Bobigny  
 F-93135 Noisy le Sec Cédex  
 Tel: (+33) 1-41 83 12 40  
 Fax: (+33) 1-48 40 47 59  
 E-Mail: forkardt.france@forkardt.com

**BUCK CHUCK**  
 2155 Traversefield Drive  
 Traverse City, MI 49686  
 USA  
 Tel: (+1) 231-995-8312  
 Fax: (+1) 231-941-2466  
 E-Mail: buck.forkardt@forkardt.com

**ITW INDIA LTD.**  
 3rd Floor, Merchant Towers, 5  
 Road No 4, Banjara Hills,  
 Hyderabad - 500 034, India  
 Tel: (+91) 40 23353781  
 Fax: (+91) 40 23353791  
 E-mail: info@itwindia.com

**N.A. WOODWORTH**  
 2002 Stephenson Hwy.  
 Troy, MI 48083  
 USA  
 Toll Free: 800.544.3823  
 E-Mail: sales@itworkholding.com  
 Website: www.itworkholding.com

[www.forkardt.com](http://www.forkardt.com)

[www.itworkholding.com](http://www.itworkholding.com)